

EMC Test Report

Application No. : LH-220302011275
Applicant : Xiamen Zhichuancheng Technology Co., Ltd.
Equipment Under Test (EUT)
EUT Name : Clay 3D Printer
Model No. : zcc4060
Serial No. : See Page 4
Trademark : N/A
Receipt Date : 2022-03-28
Test Date : 2022-03-28 to 2022-04-08
Issue Date : 2022-04-08
Standards : EN 55032: 2015/A1: 2020;
EN IEC 61000-3-2: 2019/A1: 2021
EN 61000-3-3:2013/A1:2019;
EN 55035:2017/A11:2020.
Conclusions : **PASS**

In the configuration tested, the EUT complied with the standards specified above. The EUT technically complies with the 2014/30/EU directive requirements

Test/Witness Engineer :



Approved & Authorized :



This report details the results of the testing carried out on one sample. The results contained in this test report do not relate to other samples of the same product. The manufacturer should ensure that all products in series production are in conformity with the product sample detailed in the report.

TABLE OF CONTENTS

1. General Information	4
1.1. Client Information.....	4
1.2. General Description of EUT (Equipment Under Test).....	4
1.3. Block Diagram Showing The Configuration of System Tested.....	4
1.4. Description of Support Units.....	4
1.5. Performance Criterion.....	4
1.6. Test Facility.....	5
2. TEST Results Summary	5
3. Test Equipment Used	7
4. Conducted Emission Test	9
4.1. Test Standard and Limit.....	9
4.2. Test Setup.....	9
4.3. Test Procedure.....	9
4.4. Test Condition.....	10
4.5. Test Data.....	10
5. Radiated Emission Test	15
5.1 Test Standard and Limit.....	15
5.2 Test Setup.....	15
5.3 Test Procedure.....	15
5.4 Test Condition.....	16
5.5 Test Data.....	16
6. Harmonic Current Emission Test	19
6.1 Test Standard and Limit.....	19
6.2 Test Setup.....	19
6.3 Test Procedure.....	20
6.4 Test Condition.....	20
6.5 Test Data.....	21
7. Voltage Fluctuation and Flicker Test	27
7.1 Test Standard and Limit.....	27
7.2 Test Setup.....	27
7.3 Test Procedure.....	27
7.3 Test Condition.....	28
7.4 Test Data.....	28
8. Electrostatic Discharge Immunity Test	31
8.1 Test Requirements.....	31
8.2 Test Setup.....	31
8.3 Test Procedure.....	31
8.4 Test Data.....	32
9. Radiated Electromagnetic Field Immunity Test	34
9.1 Test Requirements.....	34
9.1 Test Setup.....	34
9.2 Test Procedure.....	34
9.3 Test Data.....	35

10. Electrical Fast Transient/Burst Test.....	37
10.1 Test Requirements.....	37
10.2 Test Setup.....	37
10.3 Test Procedure.....	37
10.4 Test Data.....	38
11. Surge Immunity Test.....	40
11.1 Test Requirements.....	40
11.2 Test Setup.....	40
11.3 Test Procedure.....	40
11.4 Test Data.....	41
12. Conducted Immunity Test.....	43
12.1 Test Requirements.....	43
12.2 Test Setup.....	43
12.3 Test Procedure.....	43
12.4 Test Data.....	44
13. Voltage Dips and Interruptions Immunity Test.....	46
13.1 Test Requirements.....	46
13.2 Test Setup.....	46
13.3 Test Procedure.....	46
13.4 Test Data.....	46
14. Photographs - Constructional Details.....	48

1. General Information

1.1. Client Information

Applicant	:	Xiamen Zhichuancheng Technology Co., Ltd.
Address	:	206 Xiamen Industrial Design Center, 84 Longshan South Road, Siming District, Xiamen City
Manufacturer	:	Xiamen Zhichuancheng Technology Co., Ltd.
Address	:	206 Xiamen Industrial Design Center, 84 Longshan South Road, Siming District, Xiamen City

1.2. General Description of EUT (Equipment Under Test)

EUT Name	:	Clay 3D Printer
Model No.	:	zcc4060
Serial No.	:	zcc2000, zcc3040, zcc4060, zcc5070, zcc200H, zcc1010C
Trademark	:	N/A
Power Supply	:	AC 100-230V, 1A, 50/60Hz
Remark: All above models are identical in schematic, structure and critical components except for only different appearance; therefore, EMC testing was performed with zcc4060 only.		

1.3. Block Diagram Showing The Configuration of System Tested

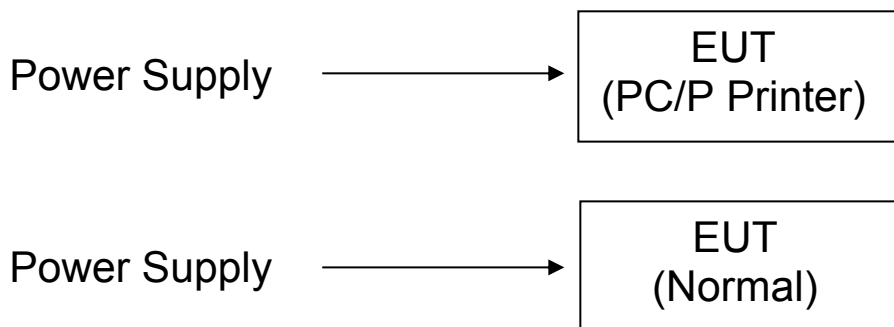

1.4. Description of Support Units

The EUT has been tested as an independent unit.

1.5. Performance Criterion

Criterion A: The equipment shall continue to operate as intended without operator intervention. No degradation of performance or loss of function is allowed below a performance level specified by the manufacturer when the equipment is used as intended.

Criterion B: After the test, the equipment shall continue to operate as intended without operator intervention. No degradation of performance or loss of function is allowed, after the application of the phenomena below a performance level specified by the manufacturer, when the equipment is used as intended.

Criterion C: Loss of function is allowed, provided the function is self-recoverable, or can be restored by the operation of the controls by the user in accordance with the manufacturer's instructions.

1.6. Test Facility

The testing report were performed by the Shenzhen LH Testing Technology Co., Ltd., in their facilities located at 201 ~ 203, building 22, Yongli Industrial Zone, Tangxi, guxing community, Xixiang street, Bao'an District, Shenzhen .

2. TEST Results Summary

EMISSION		
Description of test items	Standards	Results
Conducted disturbance at mains terminals	EN 55032: 2015/A1: 2020	Pass
Radiated Disturbance	EN 55032: 2015/A1: 2020	Pass
Harmonic current emissions	EN IEC 61000-3-2: 2019/A1: 2021	Pass
Voltage fluctuation and flicker	EN 61000-3-3:2013/A1:2019	Pass
IMMUNITY		
Description of test items	Standards	Results
Electrostatic Discharge (ESD)	EN 61000-4-2: 2009	Pass
Radio-frequency, Continuous radiated disturbance	EN IEC 61000-4-3:2020	Pass
EFT/B Immunity	EN 61000-4-4: 2012	Pass
Surge Immunity	EN 61000-4-5: 2014/A1:2017	Pass
Conducted RF Immunity	EN 61000-4-6: 2014	Pass
Power frequency magnetic field	EN 61000-4-8: 2010	N/A
Voltage dips, >95% reduction	EN IEC 61000-4-11:2020	Pass
Voltage dips, 30% reduction		
Voltage interruptions		
Note: N/A is an abbreviation for Not Applicable.		

3. Test Equipment Used

3.1. Test Equipment Used to Measure Conducted Emission					
No.	Equipment	Manufacturer	Model No.	Last Cal.	Cal. Interval
LH-EMC001	EMI Test Receiver	Rohde & Schwarz	ESCS30	Dec. 30, 2021	1 Year
LH-EMC002	AMN	Rohde & Schwarz	ENV216	Dec. 30, 2021	1 Year
LH-EMC003	AMN	SCHWARZBECK	NNBL 8226	Dec. 30, 2021	1 Year
3.2. Test Equipment Used to Measure Radiated Emission					
No.	Equipment	Manufacturer	Model No.	Last Cal.	Cal. Interval
LH-EMC004	EMI Test Receiver	Rohde & Schwarz	ESI26	Dec. 30, 2021	1 Year
LH-EMC005	Bilog Antenna	SCHWARZBECK	VULB9163	Dec. 30, 2021	1 Year
LH-EMC006	Positioning Controller	C&C	CC-C-1F	N/A	N/A
3.3. Test Equipment Used to Measure Harmonic Current/ Voltage Fluctuation and Flicker					
No.	Equipment	Manufacturer	Model No.	Last Cal.	Cal. Interval
LH-EMC007	Harmonic Flicker Test System	CI	5001ix-CTS-400	Dec. 30, 2021	1 Year
3.4. Test Equipment Used to Measure Electrostatic Discharge Immunity					
No.	Equipment	Manufacturer	Model No.	Last Cal.	Cal. Interval
LH-EMC008	ESD Tester	TESEQ	NSG437	Dec. 30, 2021	1 Year
3.5. Test Equipment Used to Measure Conducted Immunity					
No.	Equipment	Manufacturer	Model No.	Last Cal.	Cal. Interval
LH-EMC009	RF Generator	FRANKONIA	CIT-10/75	Dec. 30, 2021	1 Year
LH-EMC010	Attenuator	FRANKONIA	59-6-33	Dec. 30, 2021	1 Year
LH-EMC011	M-CDN	LUTHI	M2/M3	Dec. 30, 2021	1 Year
LH-EMC012	CDN	LUTHI	AF2	Dec. 30, 2021	1 Year
LH-EMC013	EM Injection Clamp	LUTHI	EM101	Dec. 30, 2021	1 Year
3.6. Test Equipment Used to Measure Radio Frequency Electromagnetic Fields Immunity					

No.	Equipment	Manufacturer	Model No.	Last Cal.	Cal. Interval
LH-EMC014	Signal Generator	Rohde & Schwarz	SMT03	Dec. 30, 2021	1 Year
LH-EMC015	Power Meter	Rohde & Schwarz	NRVD	Dec. 30, 2021	1 Year
LH-EMC016	Voltage Probe	Rohde & Schwarz	URV5-Z2	Dec. 30, 2021	1 Year
LH-EMC017	Voltage Probe	Rohde & Schwarz	URV5-Z2	Dec. 30, 2021	1 Year
LH-EMC018	Power Amplifier	AR	150W1000	Dec. 30, 2021	1 Year
LH-EMC019	Bilog Antenna	Chase	CBL6111C	Dec. 30, 2021	1 Year

3.7. Test Equipment Used to Measure Electrical Fast Transient/Burst Immunity

No.	Equipment	Manufacturer	Model No.	Last Cal.	Cal. Interval
LH-EMC020	Simulator	EMTEST	UCS500N5	Dec. 30, 2021	1 Year
LH-EMC021	Auto-transformer	EMTEST	V4780S2	Dec. 30, 2021	1 Year

3.8. Test Equipment Used to Measure Surge Immunity

No.	Equipment	Manufacturer	Model No.	Last Cal.	Cal. Interval
LH-EMC022	Simulator	EMTEST	UCS500N5	Dec. 30, 2021	1 Year
LH-EMC023	Coupling Clamp	EMTEST	HFK	Dec. 30, 2021	1 Year

3.9. Test Equipment Used to Measure Voltage Dips and Interruptions Immunity

No.	Equipment	Manufacturer	Model No.	Last Cal.	Cal. Interval
LH-EMC022	Simulator	EMTEST	UCS500N5	Dec. 30, 2021	1 Year
LH-EMC023	Coupling Clamp	EMTEST	HFK	Dec. 30, 2021	1 Year

3.10. Test Equipment Used to Measure Power frequency Magnetic Field

No.	Equipment	Manufacturer	Model No.	Last Cal.	Cal. Interval
LH-EMC026	Power Frequency Magnetic Field Generator	EVERFINE	EMS61000-8	Dec. 30, 2021	1 Year

4. Conducted Emission Test

4.1. Test Standard and Limit

4.1.1. Test Standard

EN 55032: 2015/A1: 2020.

4.1.2. Test Limit

Conducted Disturbance Test Limit (Class B)

Frequency	Maximum RF Line Voltage (Db μ V)	
	Quasi-peak Level	Average Level
150kHz~500kHz	66 ~ 56 *	56 ~ 46 *
500kHz~5MHz	56	46
5MHz~30MHz	60	50

4.2. Test Setup

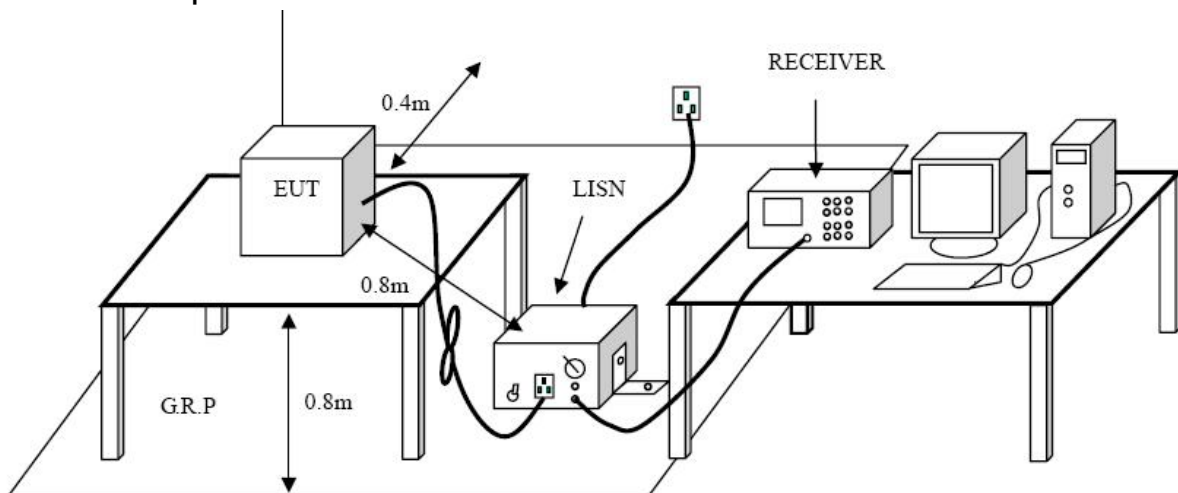

4.3. Test Procedure

The EUT was placed 0.8 meters from the horizontal ground plane with EUT being connected to the power mains through a line impedance stabilization network (LISN). All other support equipments powered from additional LISN(s). The LISN provide 50 Ohm/ 50U_h of coupling impedance for the measuring instrument.

Interconnecting cables that hang closer than 40 cm to the ground plane shall be folded back and forth in the center forming a bundle 30 to 40 cm long.

I/O cables that are not connected to a peripheral shall be bundled in the center. The end of the cable may be terminated, if required, using the correct terminating impedance. The overall length shall not exceed 1 m.

LISN at least 80 cm from nearest part of EUT chassis.

The bandwidth of EMI test receiver is set at 9kHz, and the test frequency band is from 0.15MHz to 30MHz.

4.4. Test Condition

Temperature	:	25 °C
Relative Humidity	:	48 %
Pressure	:	1010 hPa
Test Power	:	AC 230V/50Hz

4.5. Test Data

Please refer to the following pages.

Operating Condition: Normal

Test Specification: Line

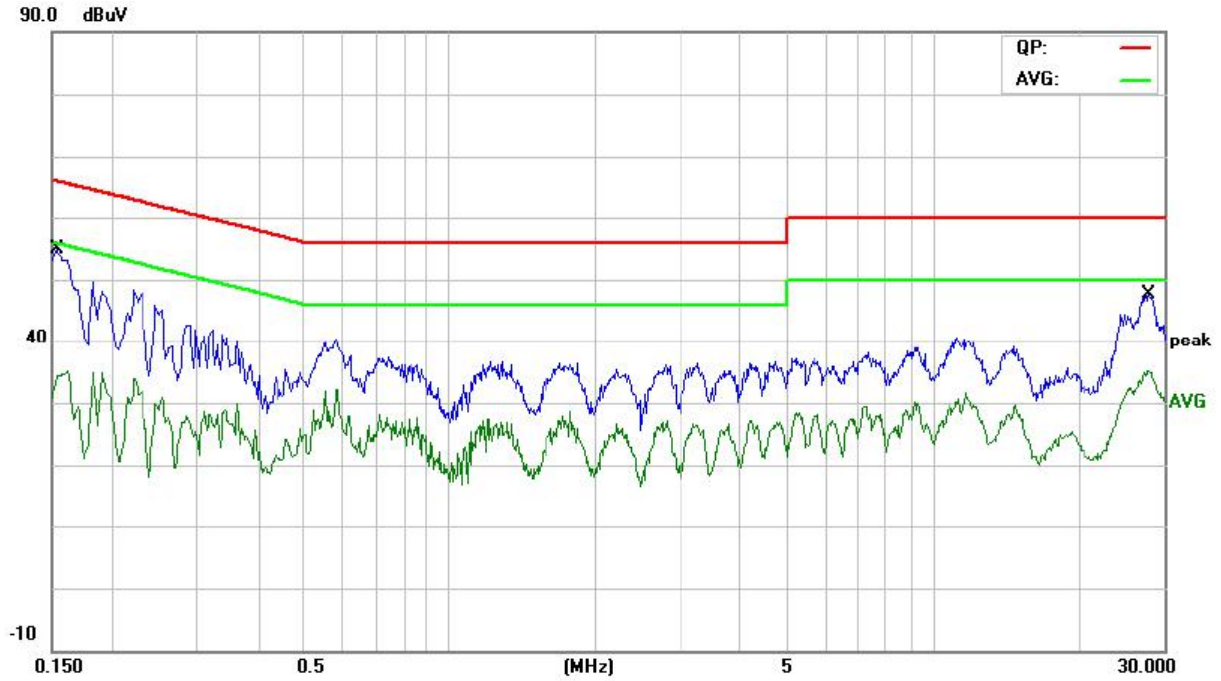

No.	Mk.	Freq. MHz	Reading Level dBuV	Correct Factor dB	Measure- ment dBuV	Limit dBuV	Over dB	Detector	Comment
1	*	0.1539	41.29	10.85	52.14	65.78	-13.64	QP	
2		0.1539	24.12	10.85	34.97	55.78	-20.81	AVG	
3		27.8980	30.35	10.10	40.45	60.00	-19.55	QP	
4		27.8980	22.88	10.10	32.98	50.00	-17.02	AVG	

Operating Condition: Normal

Test Specification: Neutral

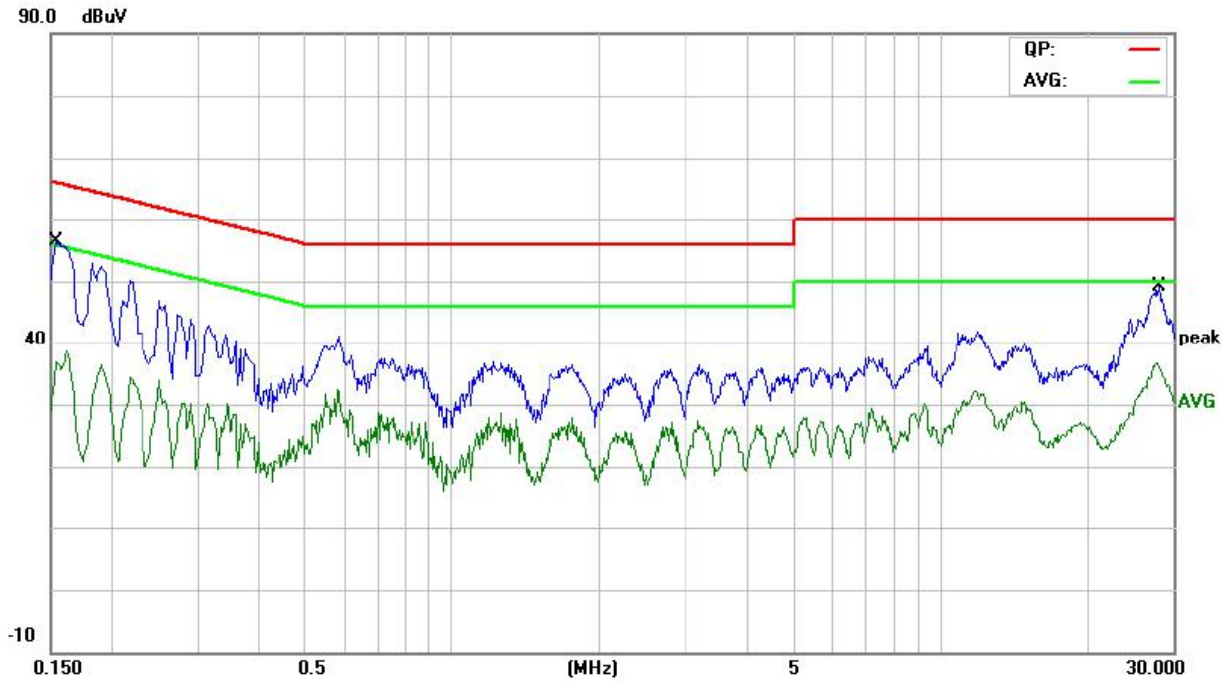

No.	Mk.	Freq. MHz	Reading Level dBuV	Correct Factor dB	Measure- ment dBuV	Limit dBuV	Over dB	Detector	Comment
1	*	0.1539	42.15	10.88	53.03	65.78	-12.75	QP	
2		0.1539	24.64	10.88	35.52	55.78	-20.26	AVG	
3		28.1380	32.08	10.12	42.20	60.00	-17.80	QP	
4		28.1380	24.44	10.12	34.56	50.00	-15.44	AVG	

Operating Condition: Normal (PC)

Test Specification: Line

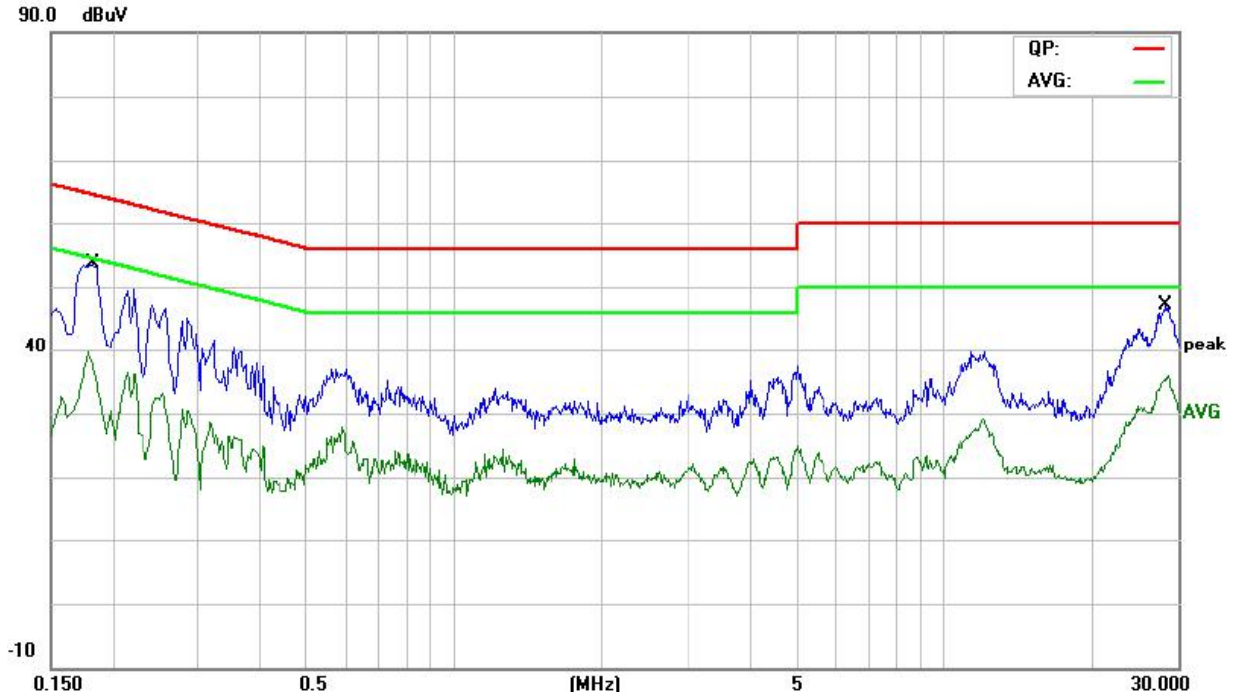

No.	Mk.	Freq. MHz	Reading Level dBuV	Correct Factor dB	Measure- ment dBuV	Limit dBuV	Over dB	Detector	Comment
1	*	0.1819	39.66	10.53	50.19	64.39	-14.20	QP	
2		0.1819	24.33	10.53	34.86	54.39	-19.53	AVG	
3		28.3780	28.78	10.12	38.90	60.00	-21.10	QP	
4		28.3780	22.47	10.12	32.59	50.00	-17.41	AVG	

Operating Condition: Normal (PC)

Test Specification: Neutral

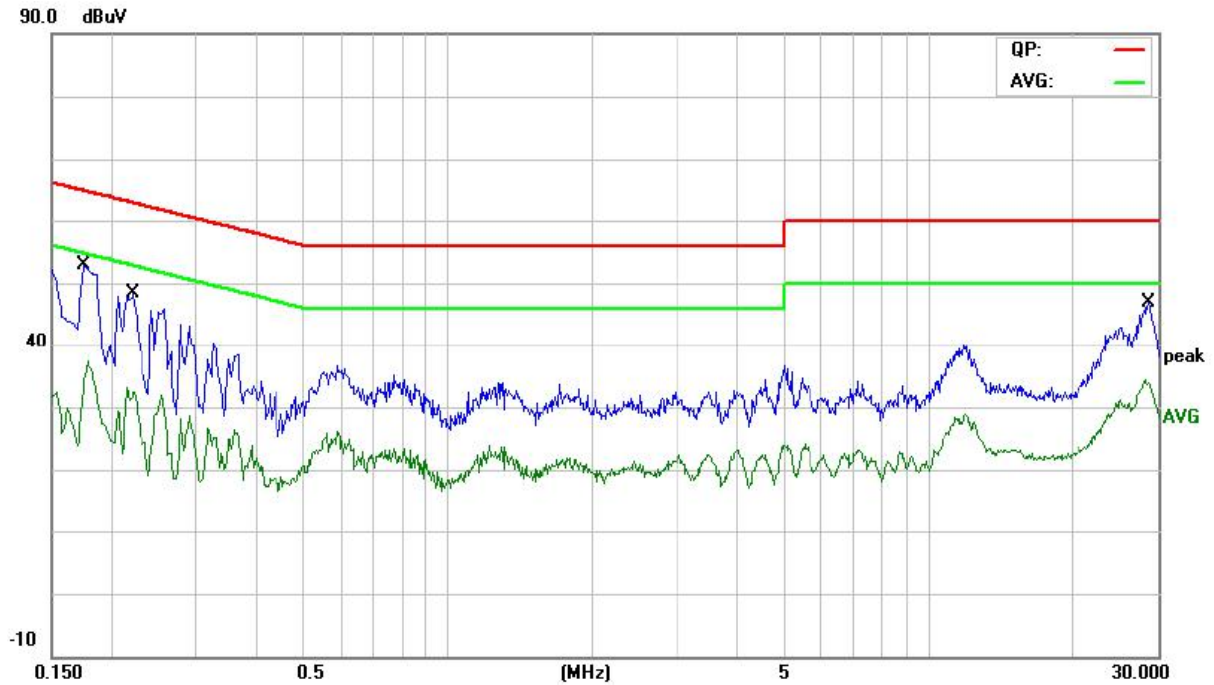

No.	Mk.	Freq. MHz	Reading Level dBuV	Correct Factor dB	Measure- ment dBuV	Limit dBuV	Over dB	Detector	Comment
1	*	0.1740	37.89	10.65	48.54	64.76	-16.22	QP	
2		0.1740	19.75	10.65	30.40	54.76	-24.36	AVG	
3		0.2220	34.00	10.19	44.19	62.74	-18.55	QP	
4		0.2220	19.14	10.19	29.33	52.74	-23.41	AVG	
5		28.6540	29.48	10.18	39.66	60.00	-20.34	QP	
6		28.6540	22.36	10.18	32.54	50.00	-17.46	AVG	

5. Radiated Emission Test

5.1 Test Standard and Limit

5.1.1. Test Standard

EN 55032: 2015/A1: 2020

5.1.2. Test Limit

Radiated Disturbance Test Limit (Class B)

Frequency	Limit (Db μ V/m)
	Quasi-peak Level
30MHz~230MHz	40
230MHz~1000MHz	47

Remark: 1. The lower limit shall apply at the transition frequency.
2. The test distance is 3m.

5.2 Test Setup

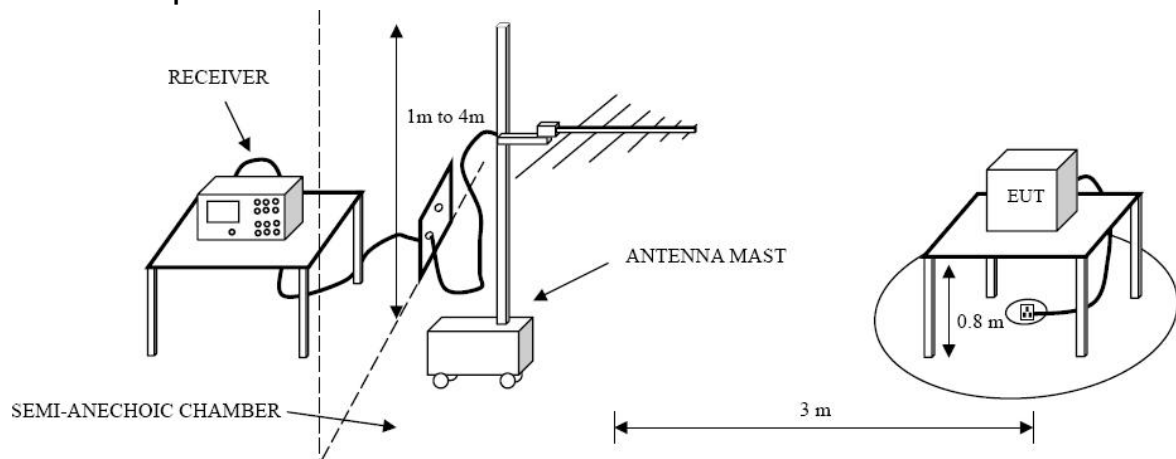

5.3 Test Procedure

The EUT was placed on the top of a rotating table 0.8 meters above the ground at a 3m. The table was rotated 360 degrees to determine the position of the highest radiation.

The height of the equipment or of the substitution antenna shall be 0.8 m; the height of the test antenna shall vary between 1 m to 4 m. Both horizontal and vertical polarizations of the antenna are set to make the measurement.

The initial step in collecting radiated emission data is a spectrum analyzer peak detector mode pre-scanning the measurement frequency range.

If the Peak Mode measured value compliance with and lower than Quasi Peak Mode Limit, the EUT shall be deemed to meet QP Limits and then no additional QP Mode measurement performed.

5.4 Test Condition

Temperature	:	25 °C
Relative Humidity	:	48 %
Pressure	:	1010 hPa
Test Power	:	AC 230V/50Hz

5.5 Test Data

Please refer to the following pages.

Operating Condition: Normal

Test Specification: Horizontal

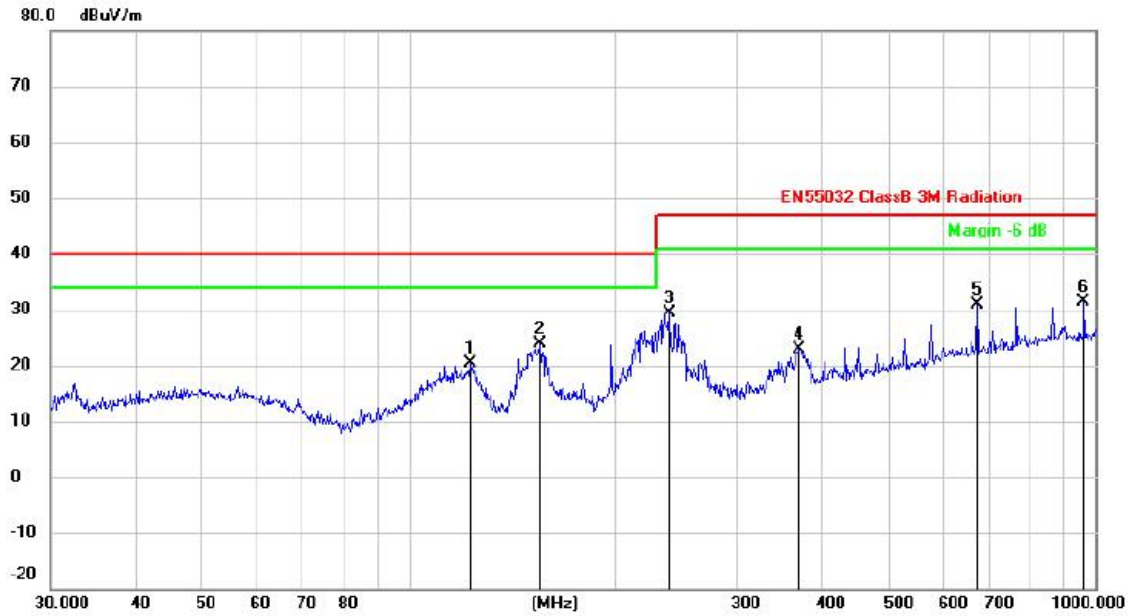

No.	Mk.	Freq. MHz	Reading Level dBuV	Correct Factor dBuV/m	Measure- ment dBuV/m	Limit dBuV/m	Over dB	Detector
1		122.8340	36.36	-16.02	20.34	40.00	-19.66	peak
2		155.3643	40.93	-17.02	23.91	40.00	-16.09	peak
3		239.1473	42.03	-12.77	29.26	47.00	-17.74	peak
4		370.7022	32.82	-9.82	23.00	47.00	-24.00	peak
5		672.8444	35.77	-4.90	30.87	47.00	-16.13	peak
6	*	962.1622	33.50	-2.00	31.50	47.00	-15.50	peak

Operating Condition: Normal

Test Specification: Vertical



No.	Mk.	Freq. MHz	Reading Level dBuV	Correct Factor dBuV/m	Measure- ment dBuV/m	Limit dBuV/m	Over dB	Detector
1		32.7486	44.08	-13.89	30.19	40.00	-9.81	peak
2		58.6126	37.40	-12.80	24.60	40.00	-15.40	peak
3		98.8324	36.72	-13.99	22.73	40.00	-17.27	peak
4	*	223.7333	44.29	-13.18	31.11	40.00	-8.89	peak
5		672.8444	37.19	-4.90	32.29	47.00	-14.71	peak
6		962.1622	37.39	-2.00	35.39	47.00	-11.61	peak

6. Harmonic Current Emission Test

6.1 Test Standard and Limit

6.1.1. Test Standard

EN IEC 61000-3-2: 2019/A1: 2021

6.1.2. Limits

Harmonic Current Test Limit (Class A)

Harmonic order (n)	Maximum permissible harmonic current (A)
Odd harmonics	
3	2.30
5	1.14
7	0.77
9	0.40
11	0.33
13	0.21
$15 \leq n \leq 39$	$0.15 \times 15/n$
Even harmonics	
2	1.08
4	0.43
6	0.30
$8 \leq n \leq 40$	$0.23 \times 8/n$

6.2 Test Setup

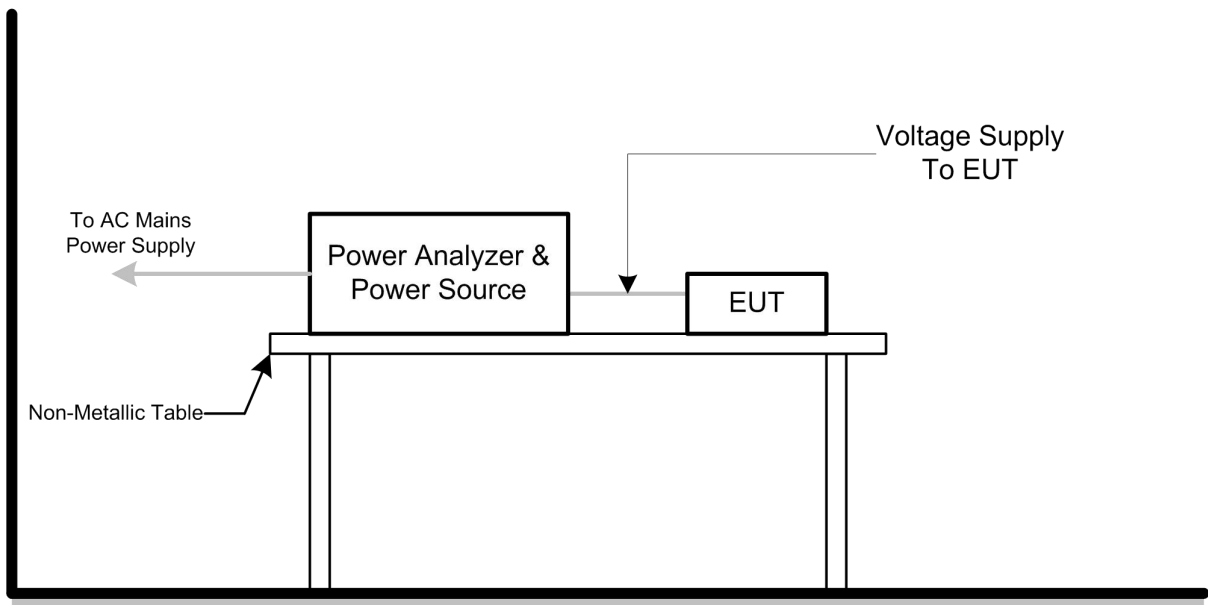

6.3 Test Procedure

The EUT was placed on the top of a wooden table 0.8 meters above the ground and operated to produce the maximum harmonic components under normal operating conditions.

The classification of EUT is according to section 5 of EN IEC 61000-3-2: 2019/A1: 2021 The EUT is classified as follows:

Class A: Balanced three-phase equipment, Household appliances excluding equipment as Class D, Tools excluding portable tools, Dimmers for incandescent lamps, audio equipment, equipment not specified in one of the three other classes.

Class B: Portable tools. Arc welding equipment which is not professional equipment.

Class C: Lighting equipment.

Class D: Equipment having a specified power less than or equal to 600 W of the following types: Personal computers and personal computer monitors and television receivers.

6.4 Test Condition

Temperature	:	25 °C
Relative Humidity	:	48 %
Pressure	:	1010 hPa
Test Power	:	AC 230V/50Hz

6.5 Test Data

Harmonics – Class-A per Ed. 3.0 (2014) (Run time)

Test category: Class-A per Ed. 3.0 (2014) (European limits)

Test Margin: 100

Tested by: LH

Start time: 15:08:27

End time: 15:18:49

Test duration (min): 10

Data file name: H-000268.cts_data

Test Result: Pass

Source qualification: Normal

Current & voltage waveforms

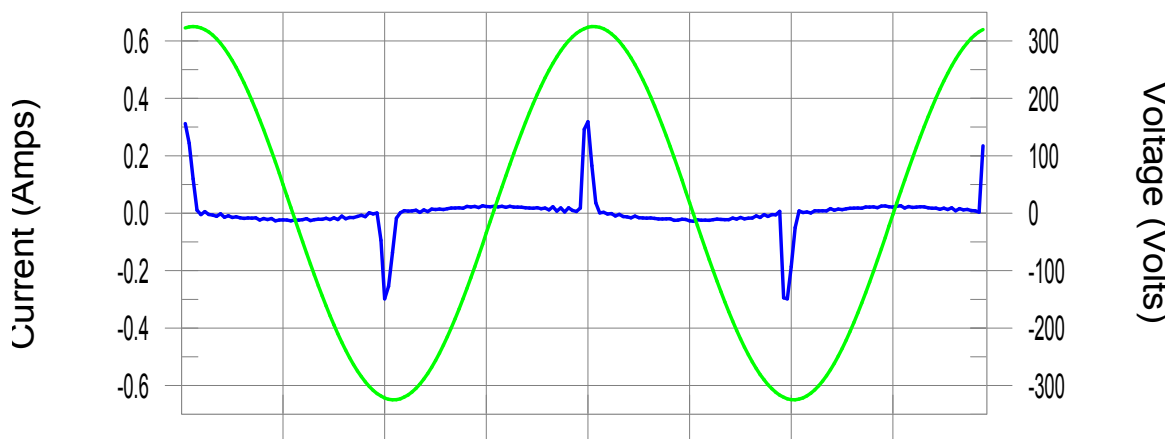

Harmonics and Class A limit line

European Limits

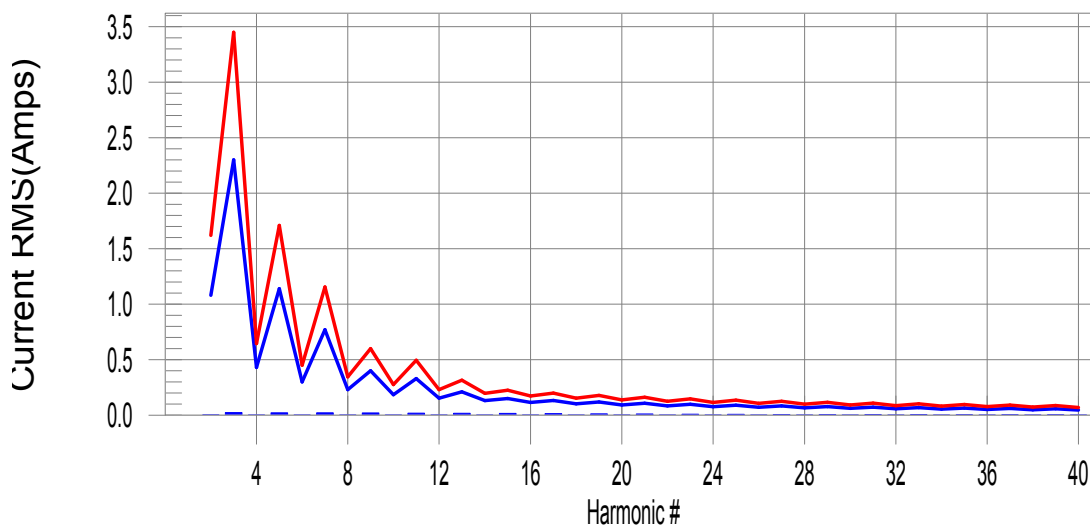

Test result: Pass Worst harmonic was #17 with 10.34% of the limit.

Current Test Result Summary (Run time)

Test category: Class-A per Ed. 3.0 (2014) (European limits)
 Test Margin: 100 Tested by: LH
 Start time: 15:08:27 End time: 15:18:49
 Test duration (min): 10 Data file name: H-000268.cts_data

Test Result: Pass Source qualification: Normal
 THC(A): 0.06 I-THD(%): 196.05 POHC(A): 0.016 POHC Limit(A): 0.283
 Highest parameter values during test:
 V_RMS (Volts): 229.94 Frequency(Hz): 50.00
 I_Peak (Amps): 0.351 I_RMS (Amps): 0.066
 I_Fund (Amps): 0.030 Crest Factor: 5.467
 Power (Watts): 5.2 Power Factor: 0.364

Harm#	Harms(avg)	100%Limit	%of Limit	Harms(max)	150%Limit	%of Limit	Status
2	0.001	1.080	0.0	0.001	1.620	0.06	Pass
3	0.022	2.300	1.0	0.023	3.450	0.67	Pass
4	0.001	0.430	0.0	0.001	0.645	0.14	Pass
5	0.022	1.140	1.9	0.022	1.710	1.27	Pass
6	0.000	0.300	0.0	0.001	0.450	0.11	Pass
7	0.021	0.770	2.7	0.021	1.155	1.83	Pass
8	0.000	0.230	0.0	0.001	0.345	0.15	Pass
9	0.020	0.400	4.9	0.020	0.600	3.33	Pass
10	0.000	0.184	0.0	0.000	0.276	0.17	Pass
11	0.018	0.330	5.6	0.019	0.495	3.77	Pass
12	0.000	0.153	0.0	0.001	0.230	0.24	Pass
13	0.017	0.210	8.1	0.017	0.315	5.48	Pass
14	0.000	0.131	0.0	0.000	0.197	0.24	Pass
15	0.015	0.150	10.2	0.016	0.225	6.97	Pass
16	0.000	0.115	0.0	0.000	0.173	0.25	Pass
17	0.014	0.132	10.3	0.014	0.199	7.07	Pass
18	0.000	0.102	0.0	0.000	0.153	0.29	Pass
19	0.012	0.118	10.1	0.012	0.178	6.94	Pass
20	0.000	0.092	0.0	0.000	0.138	0.30	Pass
21	0.010	0.107	9.5	0.011	0.161	6.65	Pass
22	0.000	0.084	0.0	0.000	0.125	0.31	Pass
23	0.009	0.098	8.8	0.009	0.147	6.19	Pass
24	0.000	0.077	0.0	0.000	0.115	0.31	Pass
25	0.007	0.090	7.8	0.008	0.135	5.63	Pass
26	0.000	0.071	0.0	0.000	0.106	0.34	Pass
27	0.006	0.083	6.7	0.006	0.125	4.96	Pass
28	0.000	0.066	0.0	0.000	0.099	0.40	Pass
29	0.004	0.078	5.5	0.005	0.116	4.35	Pass
30	0.000	0.061	0.0	0.000	0.092	0.35	Pass
31	0.003	0.073	0.0	0.004	0.109	3.73	Pass
32	0.000	0.058	0.0	0.000	0.086	0.40	Pass
33	0.003	0.068	0.0	0.003	0.102	3.28	Pass
34	0.000	0.054	0.0	0.000	0.081	0.42	Pass
35	0.002	0.064	0.0	0.003	0.096	3.03	Pass
36	0.000	0.051	0.0	0.000	0.077	0.41	Pass
37	0.002	0.061	0.0	0.003	0.091	3.01	Pass
38	0.000	0.048	0.0	0.000	0.073	0.46	Pass
39	0.002	0.058	0.0	0.003	0.087	3.07	Pass
40	0.000	0.046	0.0	0.000	0.069	0.48	Pass

Voltage Source Verification Data (Run time)

Test category: Class-A per Ed. 3.0 (2014) (European limits)
 Test Margin: 100 Tested by: LH
 Start time: 15:08:27 End time: 15:18:49
 Test duration (min): 10 Data file name: H-000268.cts_data

Test Result: Pass Source qualification: Normal

Highest parameter values during test:

V_RMS (Volts):	229.94	Frequency(Hz):	50.00
I_Peak (Amps):	0.351	I_RMS (Amps):	0.066
I_Fund (Amps):	0.030	Crest Factor:	5.467
Power (Watts):	5.2	Power Factor:	0.364

Harm#	Harmonics V-rms	Limit V-rms	% of Limit	Status
2	0.071	0.460	15.51	OK
3	0.546	2.069	26.39	OK
4	0.068	0.460	14.75	OK
5	0.052	0.920	5.64	OK
6	0.024	0.460	5.16	OK
7	0.032	0.690	4.69	OK
8	0.009	0.460	1.95	OK
9	0.026	0.460	5.55	OK
10	0.014	0.460	3.13	OK
11	0.019	0.230	8.38	OK
12	0.011	0.230	4.95	OK
13	0.019	0.230	8.40	OK
14	0.006	0.230	2.45	OK
15	0.010	0.230	4.38	OK
16	0.010	0.230	4.19	OK
17	0.015	0.230	6.39	OK
18	0.010	0.230	4.52	OK
19	0.020	0.230	8.49	OK
20	0.011	0.230	4.92	OK
21	0.015	0.230	6.67	OK
22	0.004	0.230	1.59	OK
23	0.013	0.230	5.87	OK
24	0.003	0.230	1.50	OK
25	0.010	0.230	4.42	OK
26	0.003	0.230	1.36	OK
27	0.009	0.230	4.09	OK
28	0.004	0.230	1.62	OK
29	0.009	0.230	3.94	OK
30	0.003	0.230	1.24	OK
31	0.007	0.230	3.07	OK
32	0.003	0.230	1.43	OK
33	0.006	0.230	2.82	OK
34	0.003	0.230	1.33	OK
35	0.006	0.230	2.52	OK
36	0.003	0.230	1.24	OK
37	0.004	0.230	1.54	OK
38	0.003	0.230	1.27	OK
39	0.006	0.230	2.62	OK
40	0.005	0.230	2.22	OK

Harmonics – Class-A per Ed. 3.0 (2014)(Run time)

Test category: Class-A per Ed. 3.0 (2014) (European limits)
 Test Margin: 100 Tested by: LH
 Start time: 14:41:42 End time: 14:52:03
 Test duration (min): 10 Data file name: H-000266.cts_data

Test Result: Pass Source qualification: Normal

Current & voltage waveforms

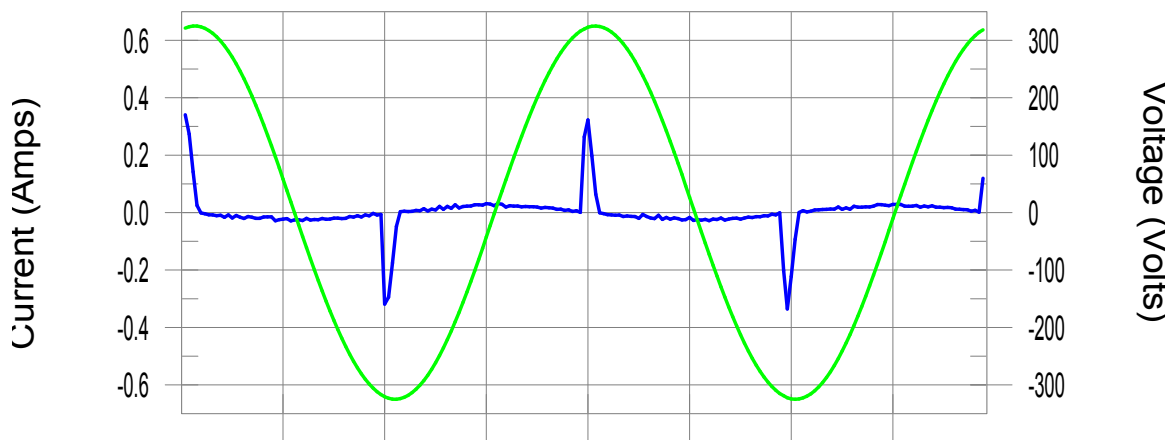

Harmonics and Class A limit line European Limits

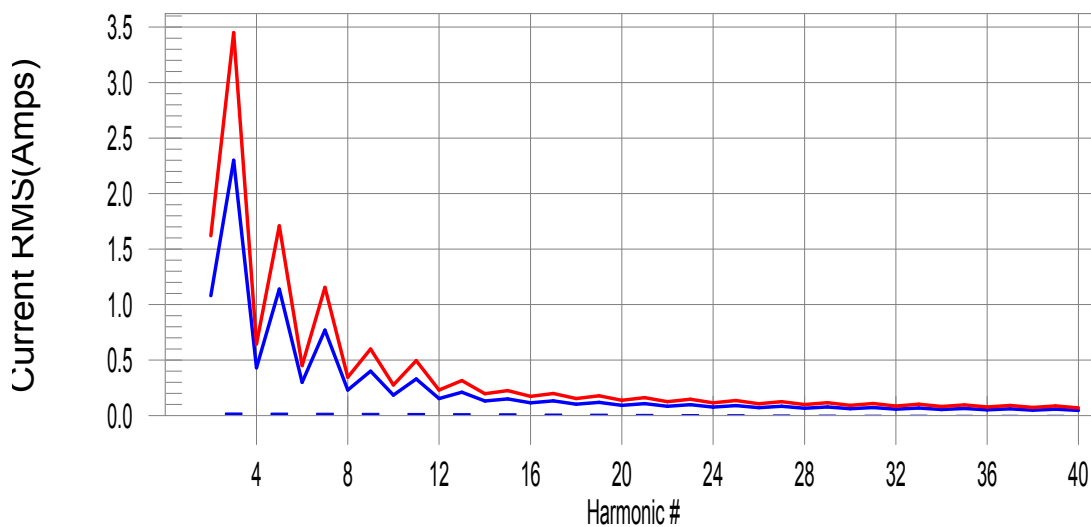

Test result: Pass Worst harmonic was #17 with 10.58% of the limit.

Current Test Result Summary (Run time)

Test category: Class-A per Ed. 3.0 (2014) (European limits)
 Test Margin: 100 Tested by: LH
 Start time: 14:41:42 End time: 14:52:03
 Test duration (min): 10 Data file name: H-000266.cts_data

Test Result: Pass Source qualification: Normal
 THC(A): 0.06 I-THD(%): 195.56 POHC(A): 0.016 POHC Limit(A): 0.283
 Highest parameter values during test:
 V_RMS (Volts): 229.93 Frequency(Hz): 50.00
 I_Peak (Amps): 0.350 I_RMS (Amps): 0.067
 I_Fund (Amps): 0.030 Crest Factor: 5.224
 Power (Watts): 5.4 Power Factor: 0.355

Harm#	Harms(avg)	100%Limit	%of Limit	Harms(max)	150%Limit	%of Limit	Status
2	0.001	1.080	0.0	0.001	1.620	0.06	Pass
3	0.023	2.300	1.0	0.024	3.450	0.69	Pass
4	0.001	0.430	0.0	0.001	0.645	0.14	Pass
5	0.022	1.140	2.0	0.022	1.710	1.31	Pass
6	0.000	0.300	0.0	0.000	0.450	0.09	Pass
7	0.021	0.770	2.8	0.022	1.155	1.88	Pass
8	0.000	0.230	0.0	0.000	0.345	0.13	Pass
9	0.020	0.400	5.1	0.020	0.600	3.42	Pass
10	0.000	0.184	0.0	0.000	0.276	0.14	Pass
11	0.019	0.330	5.7	0.019	0.495	3.85	Pass
12	0.000	0.153	0.0	0.000	0.230	0.21	Pass
13	0.017	0.210	8.3	0.018	0.315	5.59	Pass
14	0.000	0.131	0.0	0.000	0.197	0.19	Pass
15	0.016	0.150	10.5	0.016	0.225	7.06	Pass
16	0.000	0.115	0.0	0.000	0.173	0.23	Pass
17	0.014	0.132	10.6	0.014	0.199	7.10	Pass
18	0.000	0.102	0.0	0.000	0.153	0.27	Pass
19	0.012	0.118	10.3	0.012	0.178	7.00	Pass
20	0.000	0.092	0.0	0.000	0.138	0.25	Pass
21	0.010	0.107	9.8	0.011	0.161	6.62	Pass
22	0.000	0.084	0.0	0.000	0.125	0.25	Pass
23	0.009	0.098	9.0	0.009	0.147	6.13	Pass
24	0.000	0.077	0.0	0.000	0.115	0.26	Pass
25	0.007	0.090	8.0	0.007	0.135	5.49	Pass
26	0.000	0.071	0.0	0.000	0.106	0.28	Pass
27	0.006	0.083	6.9	0.006	0.125	4.84	Pass
28	0.000	0.066	0.0	0.000	0.099	0.36	Pass
29	0.005	0.078	0.0	0.005	0.116	4.16	Pass
30	0.000	0.061	0.0	0.000	0.092	0.34	Pass
31	0.004	0.073	0.0	0.004	0.109	3.62	Pass
32	0.000	0.058	0.0	0.000	0.086	0.39	Pass
33	0.003	0.068	0.0	0.003	0.102	3.21	Pass
34	0.000	0.054	0.0	0.000	0.081	0.42	Pass
35	0.003	0.064	0.0	0.003	0.096	3.07	Pass
36	0.000	0.051	0.0	0.000	0.077	0.43	Pass
37	0.003	0.061	0.0	0.003	0.091	3.12	Pass
38	0.000	0.048	0.0	0.000	0.073	0.43	Pass
39	0.003	0.058	0.0	0.003	0.087	3.30	Pass
40	0.000	0.046	0.0	0.000	0.069	0.49	Pass

Voltage Source Verification Data (Run time)

Test category: Class-A per Ed. 3.0 (2014) (European limits)
 Test Margin: 100 Tested by: LH
 Start time: 14:41:42 End time: 14:52:03
 Test duration (min): 10 Data file name: H-000266.cts_data
 Comment: OPT DT/R 1V/2V/4V/8V/16V/1D (Receiver)
 Customer: OPT

Test Result: Pass Source qualification: Normal

Highest parameter values during test:

Voltage (Vrms):	229.93	Frequency(Hz):	50.00
I_Peak (Amps):	0.350	I_RMS (Amps):	0.067
I_Fund (Amps):	0.030	Crest Factor:	5.224
Power (Watts):	5.4	Power Factor:	0.355

Harm#	Harmonics V-rms	Limit V-rms	% of Limit	Status
2	0.070	0.460	15.29	OK
3	0.546	2.069	26.39	OK
4	0.068	0.460	14.70	OK
5	0.053	0.920	5.71	OK
6	0.023	0.460	5.01	OK
7	0.034	0.690	4.99	OK
8	0.009	0.460	1.92	OK
9	0.028	0.460	6.10	OK
10	0.014	0.460	3.11	OK
11	0.021	0.230	9.06	OK
12	0.012	0.230	5.28	OK
13	0.021	0.230	9.11	OK
14	0.006	0.230	2.74	OK
15	0.011	0.230	4.68	OK
16	0.010	0.230	4.30	OK
17	0.016	0.230	6.95	OK
18	0.011	0.230	4.91	OK
19	0.020	0.230	8.68	OK
20	0.012	0.230	5.06	OK
21	0.015	0.230	6.70	OK
22	0.004	0.230	1.57	OK
23	0.014	0.230	6.24	OK
24	0.004	0.230	1.57	OK
25	0.011	0.230	4.69	OK
26	0.003	0.230	1.45	OK
27	0.010	0.230	4.40	OK
28	0.004	0.230	1.69	OK
29	0.009	0.230	3.89	OK
30	0.003	0.230	1.40	OK
31	0.007	0.230	2.92	OK
32	0.003	0.230	1.42	OK
33	0.006	0.230	2.65	OK
34	0.003	0.230	1.42	OK
35	0.005	0.230	2.38	OK
36	0.003	0.230	1.10	OK
37	0.005	0.230	2.13	OK
38	0.003	0.230	1.30	OK
39	0.006	0.230	2.81	OK
40	0.005	0.230	2.37	OK

7. Voltage Fluctuation and Flicker Test

7.1 Test Standard and Limit

7.1.1. Test Standard

EN 61000-3-3:2013/A1:2019

7.1.2. Limit

Voltage Fluctuation and Flicker Test Limit

Test Items	Limits
Pst	1.0
dc	3.3%
dmax	4.0%
dt	Not exceed 3.3% for 500ms

7.2 Test Setup

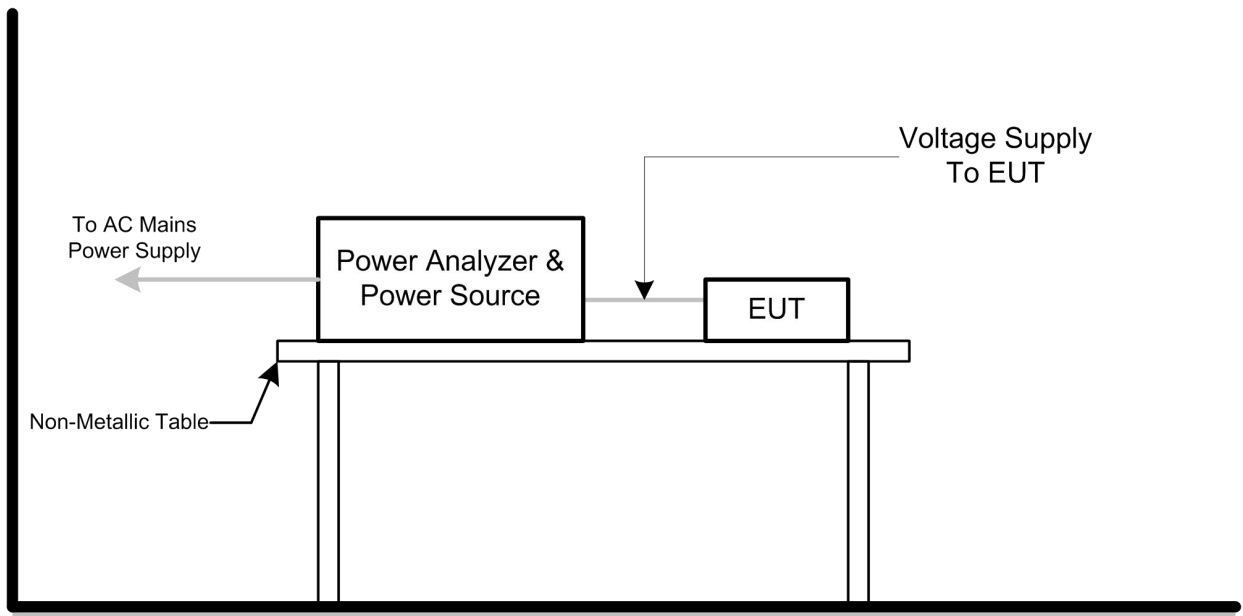

7.3 Test Procedure

7.3.1 Harmonic Current Test

Test was performed according to the procedures specified in Clause 5.0 of IEC555-2 and/or Sub-clause 6.2 of IEC/EN 61000-3-2 depend on which standard adopted for compliance measurement.

7.3.2 Fluctuation and Flickers Test:

Tests was performed according to the Test Conditions/Assessment of Voltage Fluctuations specified in Clause 5.0/6.0 of IEC555-3 and/or Clause 6.0/4.0 of IEC/EN 61000-3-3 depend on which standard adopted for compliance measurement.

All types of harmonic current and/or voltage fluctuation in this report are assessed by direct measurement using flicker-meter.

For the actual test configuration, please refer to the related Item –Block Diagram of system tested (please refer to 1.3).

7.3 Test Condition

Temperature	:	25 °C
Relative Humidity	:	48 %
Pressure	:	1010 hPa
Test Power	:	AC 230V/50Hz

7.4 Test Data

Please refer to the following pages.

Flicker Test Summary per EN/IEC61000-3-3 (Run time)

Test category: All parameters (European limits)
Test Margin: 100 **Tested by: LH**
Start time: 14:55:56 **End time: 15:06:17**
Test duration (min): 10 **Data file name: F-000267.cts_data**

Test Result: Pass

Status: Test Completed

Pst_i and limit line

European Limits

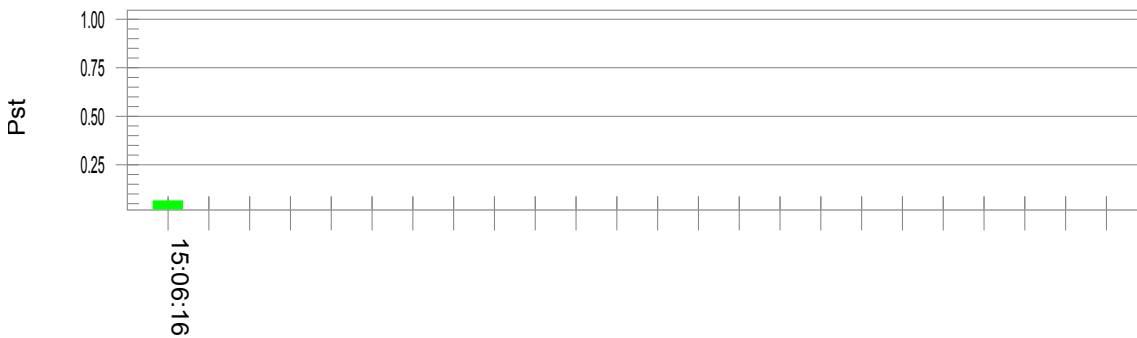

Plt and limit line



Parameter values recorded during the test:

Vrms at the end of test (Volt):	229.91			
Highest dt (%):	0.00	Test limit (%):	3.30	Pass
Time(mS) > dt:	0.0	Test limit (mS):	500.0	Pass
Highest dc (%):	0.00	Test limit (%):	3.30	Pass
Highest dmax (%):	0.00	Test limit (%):	4.00	Pass
Highest Pst (10 min. period):	0.064	Test limit:	1.000	Pass
Highest Plt (2 hr. period):	0.028	Test limit:	0.650	Pass

Flicker Test Summary per EN/IEC61000-3-3 (Run time)

Test category: All parameters (European limits)
 Test Margin: 100 Tested by: LH
 Start time: 15:23:33 End time: 15:33:54
 Test duration (min): 10 Data file name: F-000269.cts_data

Test Result: Pass Status: Test Completed

Pst_i and limit line

European Limits

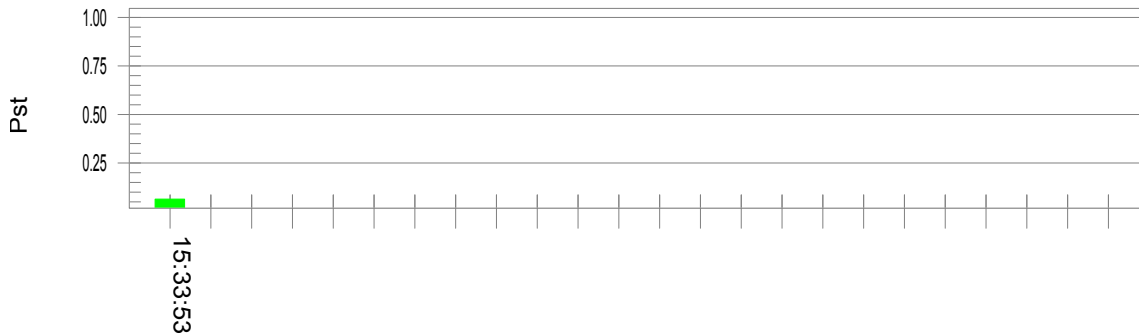

Plt and limit line

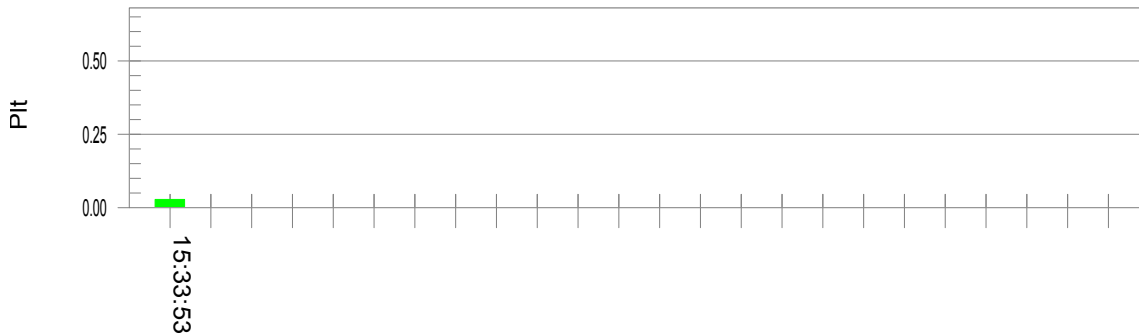

Parameter values recorded during the test:

Vrms at the end of test (Volt):	229.92			
Highest dt (%):	0.00	Test limit (%):	3.30	Pass
Time(mS) > dt:	0.0	Test limit (mS):	500.0	Pass
Highest dc (%):	0.00	Test limit (%):	3.30	Pass
Highest dmax (%):	0.00	Test limit (%):	4.00	Pass
Highest Pst (10 min. period):	0.064	Test limit:	1.000	Pass
Highest Plt (2 hr. period):	0.028	Test limit:	0.650	Pass

8. Electrostatic Discharge Immunity Test

8.1 Test Requirements

8.1.1 Test Standard

EN 55035:2017/A11:2020 (EN 61000-4-2: 2009)

8.1.2 Test Level

Level	Test Voltage Contact Discharge (Kv)	Test Voltage Air Discharge (Kv)
1	±2	±2
2	±4	±4
3	±6	±8
4	±8	±15
X	Special	Special

8.1.3 Performance criterion: **B**

8.2 Test Setup

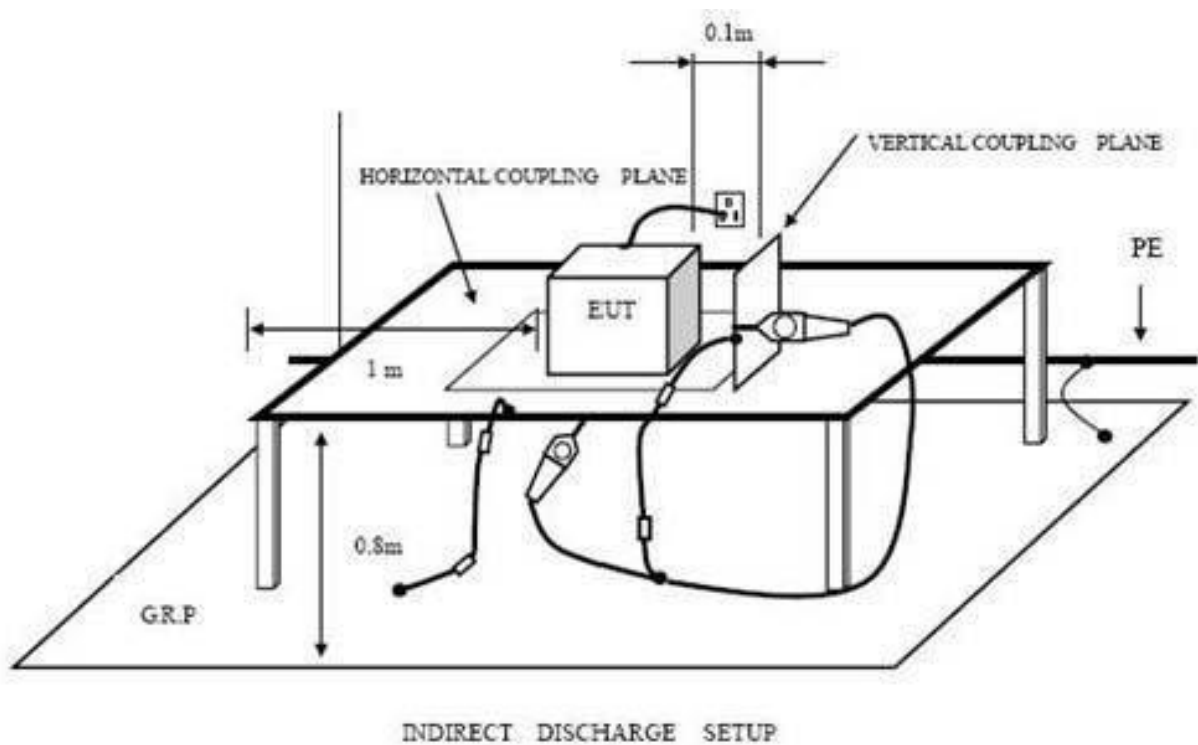

8.3 Test Procedure

8.3.1 Air Discharge:

This test is done on a non-conductive surface. The round discharge tip of the discharge electrode shall be approached as fast as possible to touch the EUT. After each discharge, the discharge electrode shall be removed from the EUT. The generator is then re-triggered for a new single discharge and repeated 10 times for each pre-selected test point. This procedure shall be repeated until all the air discharge completed.

8.3.2 Contact Discharge:

All the procedure shall be same as air discharge. Except that the tip of the discharge electrode shall touch the EUT before the discharge switch is operated.

8.3.3 Indirect discharge for horizontal coupling plane

At least 10 single discharges (in the most sensitive polarity) shall be applied at the front edge of each HCP opposite the center point of each unit (if applicable) of the EUT and 0.1m from the front of the EUT. The long axis of the discharge electrode shall be in the plane of the HCP and perpendicular to its front edge during the discharge.

8.3.4 Indirect discharge for vertical coupling plane

At least 10 single discharges (in the most sensitive polarity) shall be applied to the center of one vertical edge of the coupling plane. The coupling plane, of dimensions 0.5m X 0.5m, is placed parallel to, and positioned at a distance of 0.1m from the EUT. Discharges shall be applied to the coupling plane, with this plane in sufficient different positions that the four faces of the EUT are completely illuminated.

8.4 Test Data

Please refer to the following pages.

Electrostatic Discharge Test Result

EUT	: Clay 3D Printer	M/N	: zcc4060
Temperature	: 22°C	Humidity	: 50%
Power supply	: AC230V/50Hz	Test Mode	: Normal
Criterion: B			
Air Discharge: $\pm 8\text{kV}$ Contact Discharge: $\pm 4\text{kV}$			
For each point positive 10 times and negative 10 times discharge.			
Location	Kind A-Air Discharge C-Contact Discharge		Result
Nonconductive Enclosure	A		PASS
Slot of the EUT	A		PASS
LED	A		PASS
Port	A		PASS
Conductive Enclosure	C		PASS
Screw	C		PASS
HCP	C		PASS
VCP of front	C		PASS
VCP of rear	C		PASS
VCP of left	C		PASS
VCP of right	C		PASS
Remark:			

9. Radiated Electromagnetic Field Immunity Test

9.1 Test Requirements

9.1.1. Test Standard

EN 55035:2017/A11:2020 (EN IEC 61000-4-3:2020)

9.1.2. Test Level

Level	Field Strength V/m
1	1
2	3
3	10
X	Special

9.1.3. Performance criterion: **A**

9.1 Test Setup

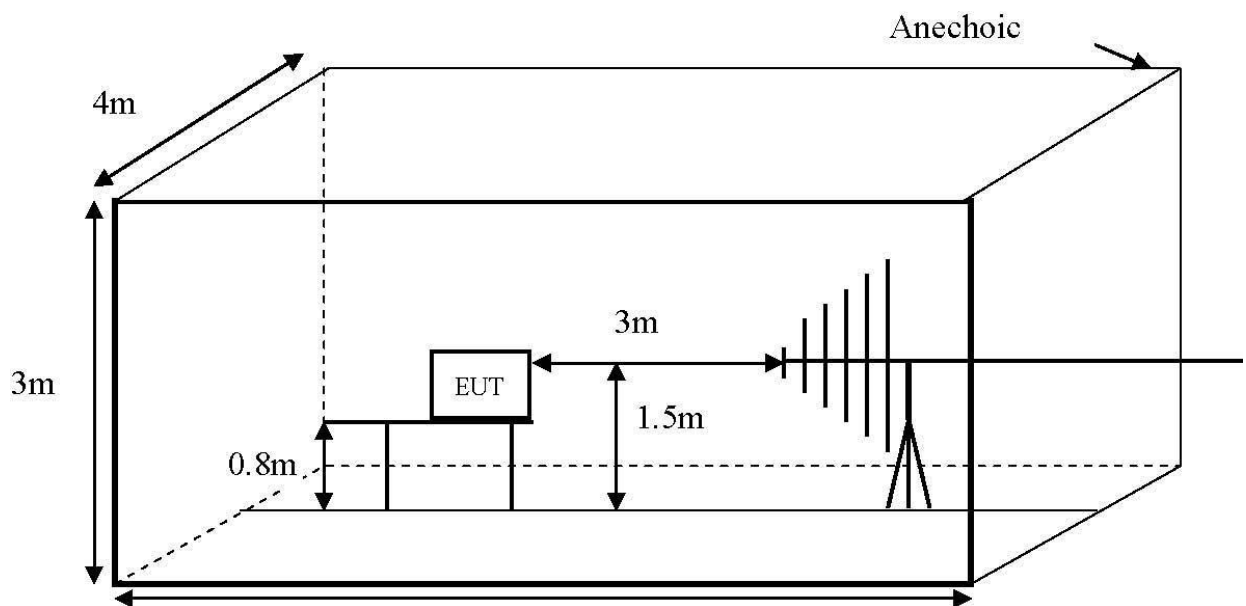

9.2 Test Procedure

The EUT are placed on a table, which is 0.8 meter high above the ground. The EUT is set 3 meters away from the transmitting antenna, which is mounted on an antenna tower. Both horizontal and vertical polarization of the antenna is set on test. Each of the four sides of the EUT must be faced this transmitting antenna and measured individually.

In order to judge the EUT performance, a camera is used to monitor its screen.

All the scanning conditions are as following:

Condition of Test	Remark
Fielded strength	3V/m (Severity Level 2)
Radiated signal	Modulated
Scanning frequency	80-1000MHz
Sweep time of radiated	0.0015 Decade/s
Dwell time	1 Sec.

9.3 Test Data

Please refer to the following pages.

RF Field Strength Susceptibility Test Results

EUT	: <u>Clay 3D Printer</u>	M/N	: <u>zcc4060</u>	
Temperature	: <u>22°C</u>	Humidity	: <u>50%</u>	
Power supply	: <u>AC230V/50Hz</u>	Test Mode	: <u>Normal</u>	
Criterion: A				
Modulation: Unmodulated				
Pulse: AM 1KHz 80%				
	Frequency Rang 1		Frequency Rang 2	
	80~1000MHz		/	
	Horizontal	Vertical	Horizontal	Vertical
Front	PASS	PASS	/	/
Right	PASS	PASS	/	/
Rear	PASS	PASS	/	/
Left	PASS	PASS	/	/
Remark:				

10. Electrical Fast Transient/Burst Test

10.1 Test Requirements

10.1.1. Test Standard

EN 55035:2017/A11:2020 (EN 61000-4-4: 2012)

10.1.2. Level

Open Circuit Output Test Voltage $\pm 10\%$		
Level	On Switching Adapter Lines	On I/O (Input/Output) Signal data and control lines
1	0.5 KV	0.25 KV
2	1 KV	0.5 KV
3	2 KV	1 KV
4	4 KV	2 KV
X	Special	Special

10.1.3. Performance criterion: B

10.2 Test Setup

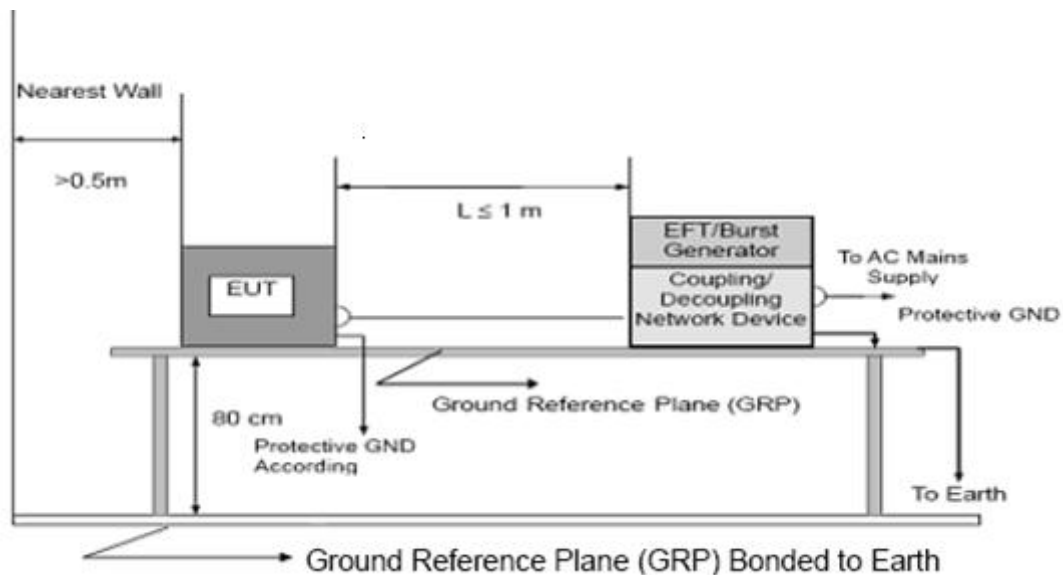

10.3 Test Procedure

10.3.1 For input and output AC power ports:

The EUT is connected to the power mains by using a coupling device which couples the EFT interference signal to AC power lines. Both polarities of the test voltage should be applied during compliance test and the duration of the test is 1 minute.

10.3.2 For signal lines and control lines ports:

A coupling clamp is use to couple the EFT interference signal to the signal and control lines. Both polarities of the test voltage should be applied during compliance test and the duration of the test is 1 minute.

10.3.3For DC input and DC output power ports:

The EUT is connected to the power mains by using a coupling device which couples the EFT interference signal to AC power lines. Both polarities of the test voltage should be applied during compliance test and the duration of the test is 1 minute.

10.4 Test Data

Please refer to the following pages.

Electrical Fast Transient/Burst Test Results

EUT : <u>Clay 3D Printer</u>	M/N : <u>zcc4060</u>		
Temperature : <u>22°C</u>	Humidity : <u>50%</u>		
Power supply : <u>AC230V/50Hz</u>	Test Mode : <u>Normal</u>		
Criterion: B			
Line : <input checked="" type="checkbox"/> AC Mains Coupling : <input checked="" type="checkbox"/> Direct			
Line : <input type="checkbox"/> Signal <input type="checkbox"/> I/O Cable Coupling : <input type="checkbox"/> Capacitive			
Line	Voltage(kV)	Result(+)	Result(-)
L	1.0	Pass	Pass
N	1.0	Pass	Pass
L-N	1.0	Pass	Pass
PE	/	/	/
L-PE	/	/	/
N-PE	/	/	/
L-N-PE	/	/	/

11. Surge Immunity Test

11.1 Test Requirements

11.1.1. Test Standard

EN 55035:2017/A11:2020 (EN 61000-4-5: 2014/A1:2017)

11.1.2. Level

Severity Level	Open-Circuit Test Voltage kV
1	1.5
2	1.0
3	1.0
4	4.0
*	Special

11.1.3. Performance criterion: **B**

11.2 Test Setup

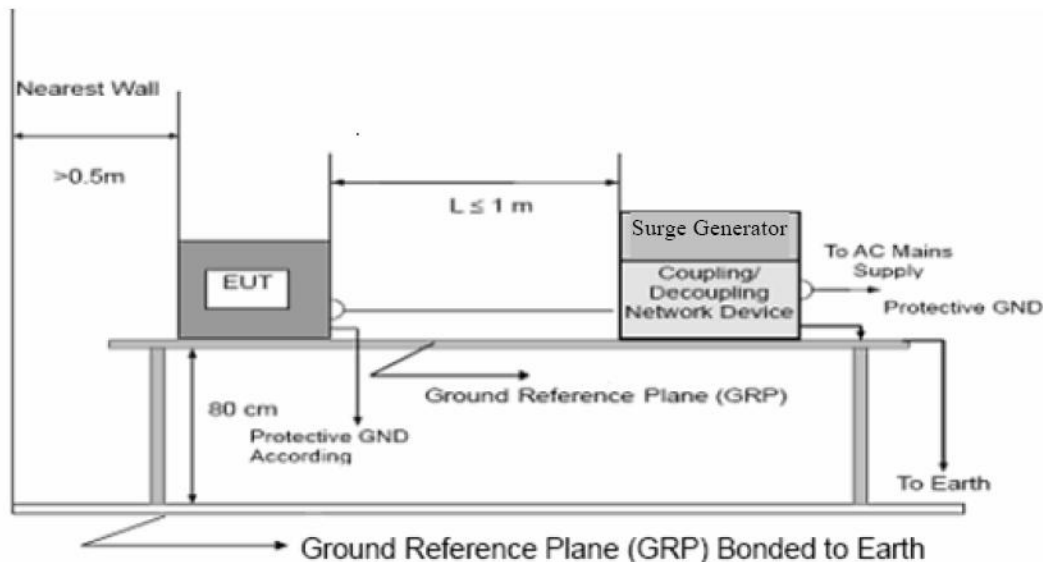

11.3 Test Procedure

11.3.1 Set up the EUT and test generator as shown on Section 11.1.2.

11.3.2 For line to line coupling mode, provide a 1.0 KV 1.2/50us voltage surge

(at open-circuit condition) and 8/20us current surge to EUT selected points.

11.3.3 At least 5 positive and 5 negative (polarity) tests with a maximum 1/min repetition rate are conducted during test.

11.3.4 Different phase angles are done individually.

11.3.5 Record the EUT operating situation during compliance test and decide the EUT immunity criterion for above each test.

11.4 Test Data

Please refer to the following pages.

Surge Immunity Test Results

EUT	: Clay 3D Printer	M/N	: zcc4060	
Temperature	: 22°C	Humidity	: 50%	
Power supply	: AC230V/50Hz	Test Mode	: Normal	
Criterion: B				
Injected Line	Voltage(kV)	Phase	Result	
			(+)	(-)
L-N	1.0	0°	Pass	Pass
		90°	Pass	Pass
		180°	Pass	Pass
		270°	Pass	Pass
L-PE	2.0	0°	/	/
		90°	/	/
		180°	/	/
		270°	/	/
N-PE	2.0	0°	/	/
		90°	/	/
		180°	/	/
		270°	/	/
L-N-PE	2.0	0°	/	/
		90°	/	/
		180°	/	/
		270°	/	/

12. Conducted Immunity Test

12.1 Test Requirements

12.1.1. Test Standard

EN 55035:2017/A11:2020 (EN 61000-4-6: 2014)

12.1.2. Level

Level	Voltage Level (e.m.f.) V
1	1
2	3
3	10
X	Special

12.1.3. Performance criterion: **A**

12.2 Test Setup

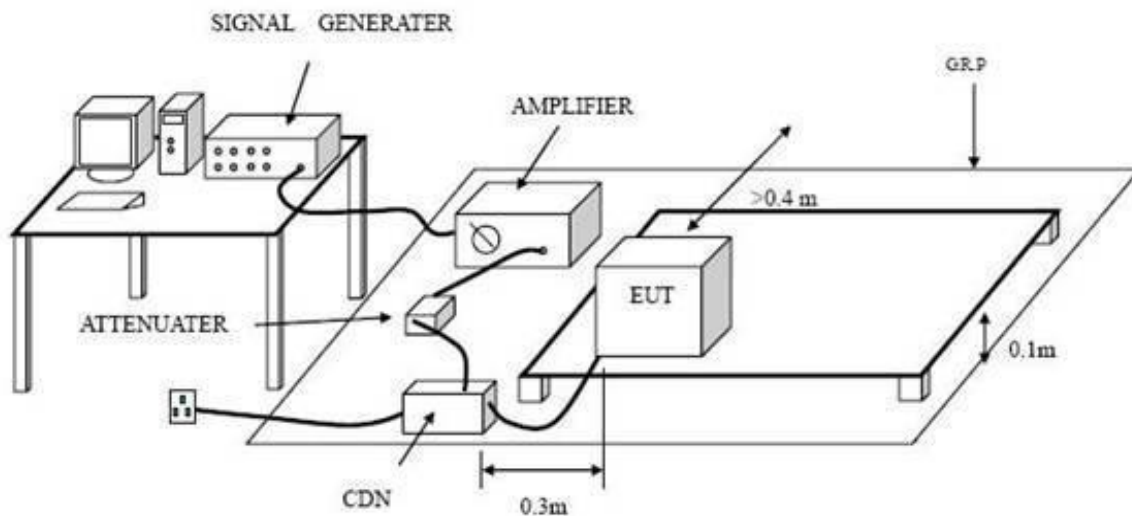

12.3 Test Procedure

12.3.1 Set up the EUT, CDN and test generators.

12.3.2 Let the EUT work in test mode and test it.

12.3.3 The EUT are placed on an insulating support 0.1m high above a ground reference plane. CDN (coupling and decoupling device) is placed on the ground plane about 0.3m from EUT. Cables between CDN and EUT are as short as possible, and their height above the ground reference plane shall be between 30 and 50 mm (where possible).

12.3.4 The disturbance signal description below is injected to EUT through CDN.

12.3.5 The EUT operates within its operational mode(s) under intended climatic conditions after power on.

12.3.6 The frequency range is swept from 0.150MHz to 80MHz using 3V signal level, and with the disturbance signal 80% amplitude modulated with a 1KHz sine wave.

12.3.7 The rate of sweep shall not exceed 1.5×10^{-3} decades/s. Where the frequency is swept incrementally, the step size shall not exceed 1% of the start and thereafter 1% of the preceding frequency value.

12.3.8 Recording the EUT operating situation during compliance testing and decide the EUT immunity criterion.

12.4 Test Data

Please refer to the following pages.

Injected Currents Susceptibility Test Results

EUT : <u>Clay 3D Printer</u>		M/N : <u>zcc4060</u>	
Temperature : <u>22°C</u>		Humidity : <u>50%</u>	
Power supply : <u>AC230V/50Hz</u>		Test Mode : <u>Transferring Video Signal</u>	
Criterion: A			
Frequency Range (MHz)	Injected Position	Voltage Level (e.m.f.)	Result
0.15 ~ 80	AC Mains	3V(rms), Unmodulated	PASS
0.15 ~ 80	DC Mains	3V(rms), Unmodulated	/
0.15 ~ 80	Signal Line	3V(rms), Unmodulated	/

13. Voltage Dips and Interruptions Immunity Test

13.1 Test Requirements

13.1.1. Test Standard

EN 55035:2017/A11:2020 (EN IEC 61000-4-11:2020)

13.1.2. Level

Test Level for Voltage Dips and Interruptions

Test Level %U _T	Voltage dip and short interruptions %U _T	Duration (in period)
0	100	250
0	100	0.5
70	30	25
40	60	5

13.1.3. Performance criterion: **B&C**

13.2 Test Setup

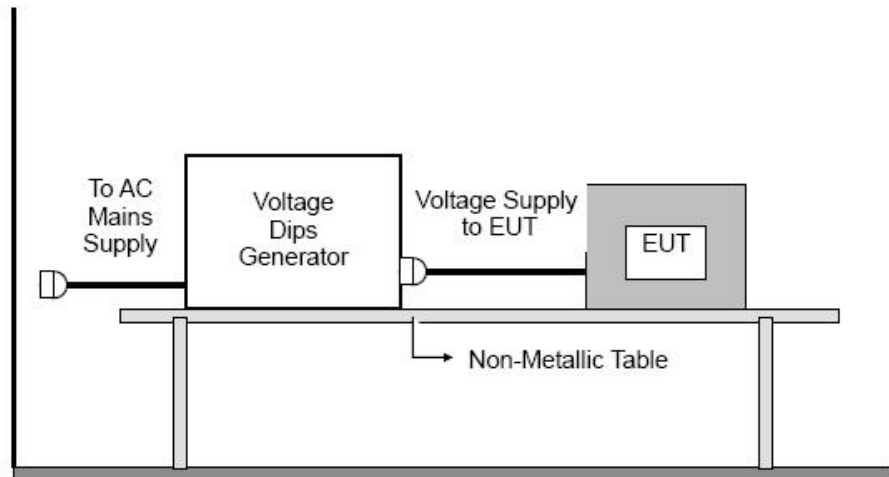

13.3 Test Procedure

Set up the EUT and test generator as shown above. The EUT is tested for each selected combination of test level and duration with a sequence of three dips/interruptions with intervals of 10s minimum.

13.4 Test Data

Voltage Dips and Interruptions Test Results

EUT	: Clay 3D Printer	M/N	: zcc4060	
Temperature	: 22°C	Humidity	: 50%	
Power supply	: AC230V/50Hz	Test Mode	: Normal	
Criterion: B&C				
Test Level % U _T	Voltage Dips & Short Interruptions % U _T	Duration (in period)	Phase Angle	Result
0	100	250P	0°~360°	PASS
70	30	25P	0°~360°	PASS
0	100	0.5P	0°~360°	PASS
Remark: U _T is the rated voltage for the equipment.				

14. Photographs - Constructional Details

Photo 1 Appearance of EUT



Photo 2 Appearance of EUT



Photo 3 Appearance of EUT



Photo 4 Appearance of EUT



END OF REPORT